



## TECHNICAL ALERT No. 17-06

---

### Requirements of Photographs for BMA documents issued to Seafarers

---

#### 1. Introduction

- 1.1. This Technical Alert is to inform all parties of the revised minimum standards of photograph for a BMA issued seafarer document.
- 1.2. This Technical Alert should be read in conjunction with *BMA Information Bulletin* nos. 107, 108 and 124; and *Technical Alerts* 15-06 and 17-03.

#### 2. General

- 2.1. The photograph should be a passport picture that is:
  - a) Printed to a professional standard and scanned to a high resolution;
  - b) Taken within the last six months;
  - c) In colour;
  - d) Taken against a plain, light coloured background;
  - e) Clear and in focus;
  - f) Without any marks or damage; and
  - g) Unaltered by computer software.
- 2.2. The picture of the seafarer must show:
  - a) A close-up of the seafarer's full head and upper shoulders;
  - b) Contain no other objects or people;
  - c) Be in clear contrast to the background; and
  - d) The seafarer:
    - facing forward with a neutral expression,

- with eyes open, visible and free from reflection or glare from glasses,
- with no hair in front of the seafarer's eyes or shadows covering the seafarer's face,
- with no head covering except for religious coverings,
- with nothing covering the seafarer's face.

2.3 Sunglasses or tinted glasses cannot be worn. Prescription glasses used for sight correction can be worn but must be free from glare or reflections and the seafarer's eyes must be clearly visible.

2.4. The image size and layout should be as noted in the diagram below:

#### Photographic Template

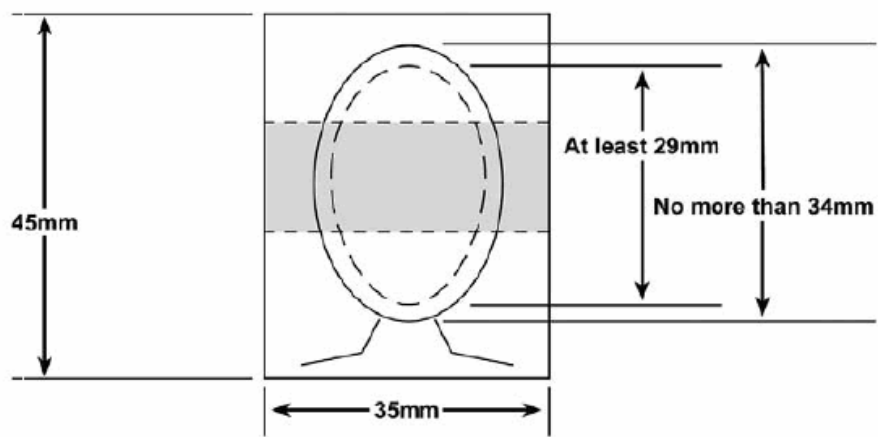

- 2.5. The photograph must be cropped and uploaded onto the Bahamas Online Registration Information System (BORIS) in the correct format and layout. To ensure no accidental skewing of the picture or seafarer's features, photographs cannot be edited by the BMA once they have been uploaded to BORIS.
- 2.6. Photographs must be saved as a JPEG (.jpg) and a minimum 150 DPI.
- 2.7. Any photograph that does not meet the above stated requirements will be rejected and this can cause delays to the issuance of the seafarer's documentation.

### 3. Validity

3.1. This Technical Alert is valid until further notice.

### 4. Revision History

Rev.0 (30th June 2017) – First issue